

HWA

**EVOLUTION  
IS OUR  
HERITAGE**

"WE WANTED TO DO MOTORSPORTS  
AND MAKE THE BEST CAR  
IN THE WORLD EVEN BETTER."

HANS WERNER AUFRECHT  
THE FOUNDER OF AMG AND HWA

1967

1992

1993

2023

2024

2025



30 YEARS AGO, KLAUS LUDWIG WON THE DTM FOR MERCEDES-BENZ FOR THE FIRST TIME AND THUS



LAI D THE FOUNDATION FOR THE PATH TO BECOMING THE MOST SUCCESSFUL BRAND IN DTM HISTORY.



1967

1992

1993

2023

2024

2025

"IT'S NOT JUST ABOUT WINNING,  
IT'S ABOUT PUSHING YOUR CAR TO THE  
ABSOLUTE LIMIT."

BERND SCHNEIDER

1967

1992

1993

2023

2024

2025



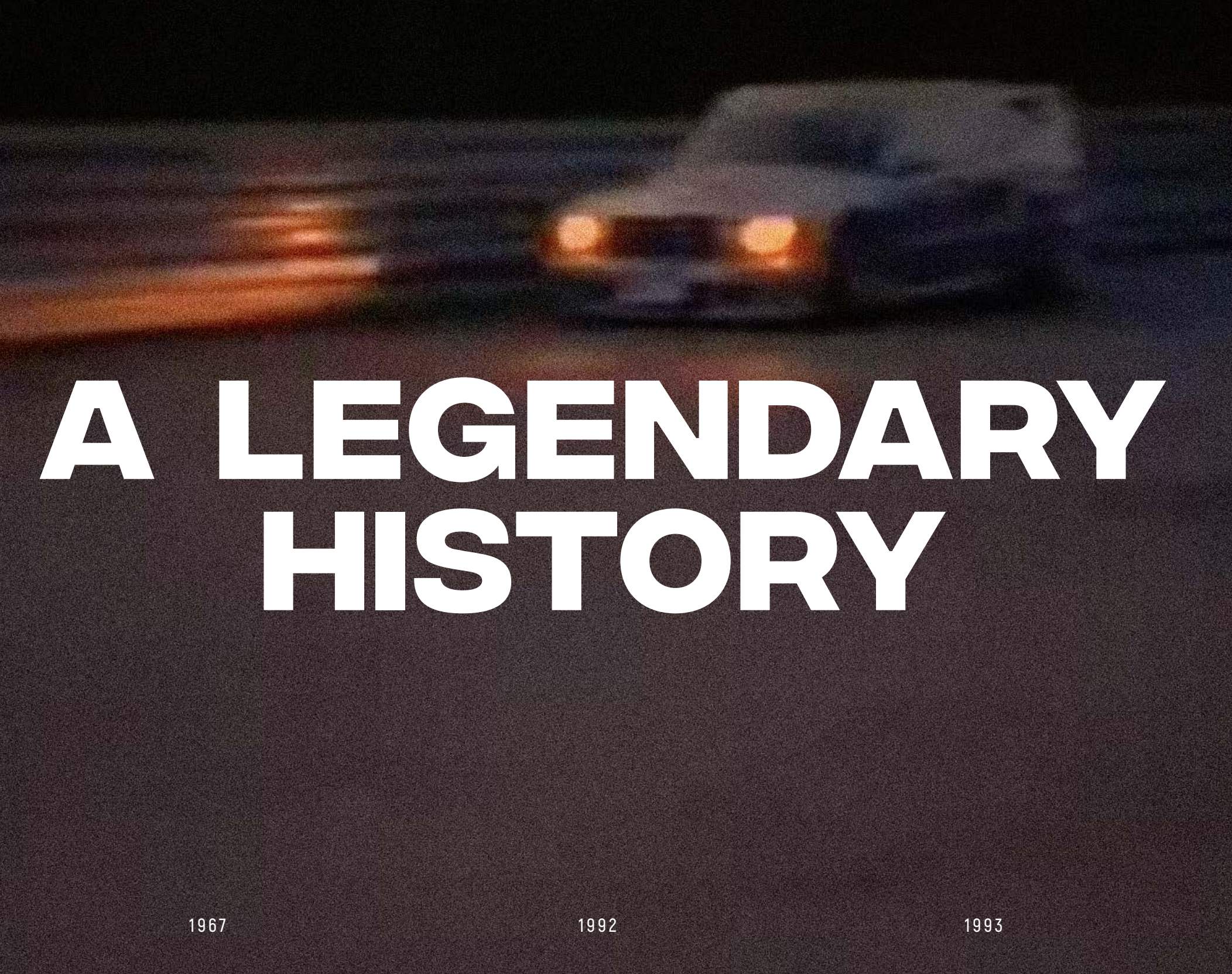

**A LEGENDARY  
HISTORY**

1967

1992

1993



**WHICH  
WE CONTINUE**

2023

2024

2025

# HWA EVO RESTOMOD

THE REINTERPRETATION OF A CLASSIC FROM THE 90S, WITH THE AIM OF CREATING A SYNTHESIS OF PAST AND MODERN HIGH-QUALITY TECHNOLOGY.

1967

1992

1993

2023

2024

2025

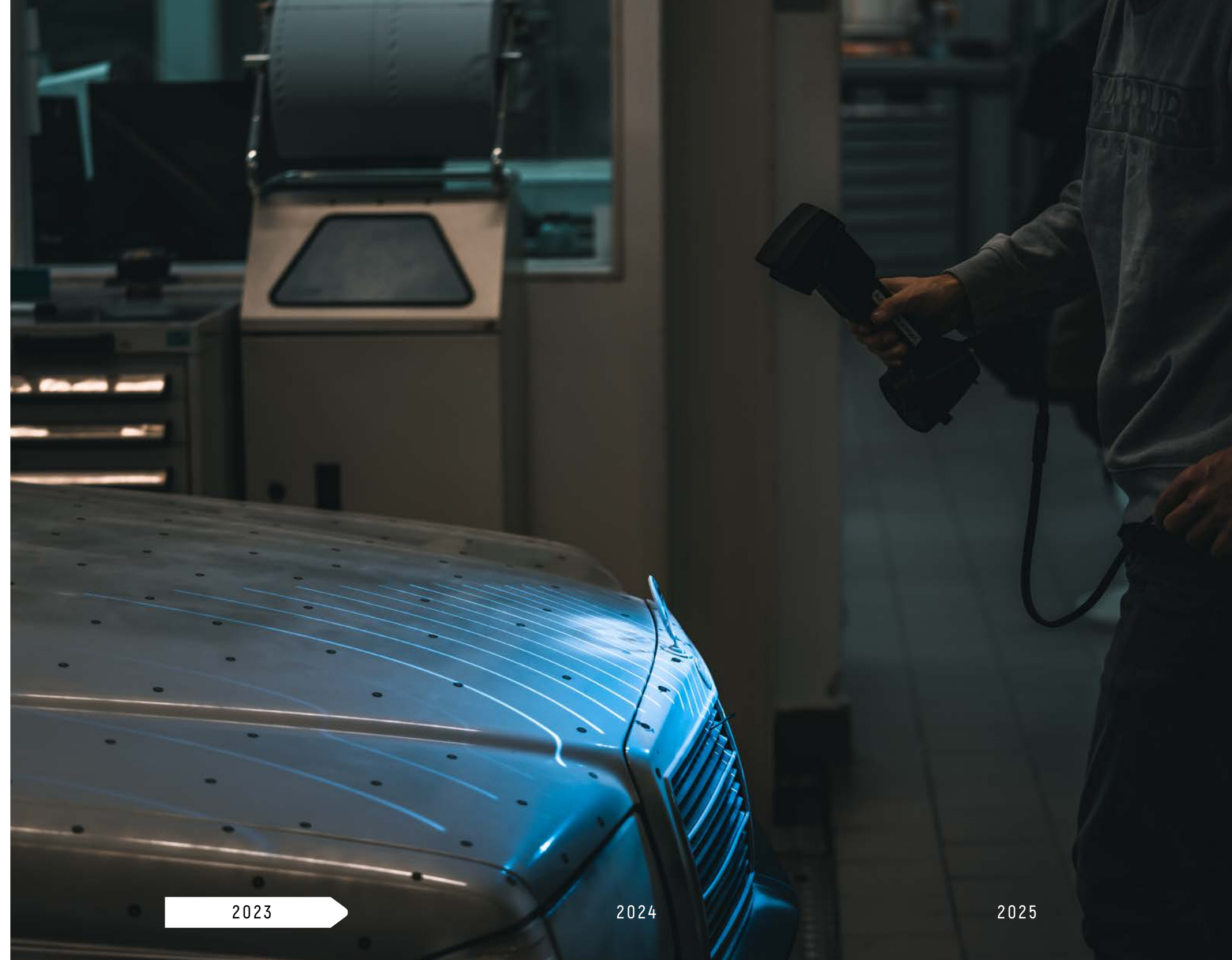

**LIMITED EDITION**  
100 PIECES

**PRICE OF SALE**  
FROM 714,000 €  
[PLUS: VALUE ADDED TAX]

1967

1992

**VEHICLE DELIVERIES**  
FROM 2025 ONWARDS

1993

**40 YEARS**  
AFTER THE FIRST  
„MERCEDES-BENZ 190“

**25 YEARS**  
OF HWA

2023

**USE CASE**  
ROAD-LEGAL

**AFTER 30 YEARS WE  
REINTRODUCE A LEGEND**  
FIRST EVER WINNING DTM CHAMPIONSHIP  
FOR A „190 E.2.5 - 6 EVOLUTION II“

2024

2025



# DESIGN CONCEPT

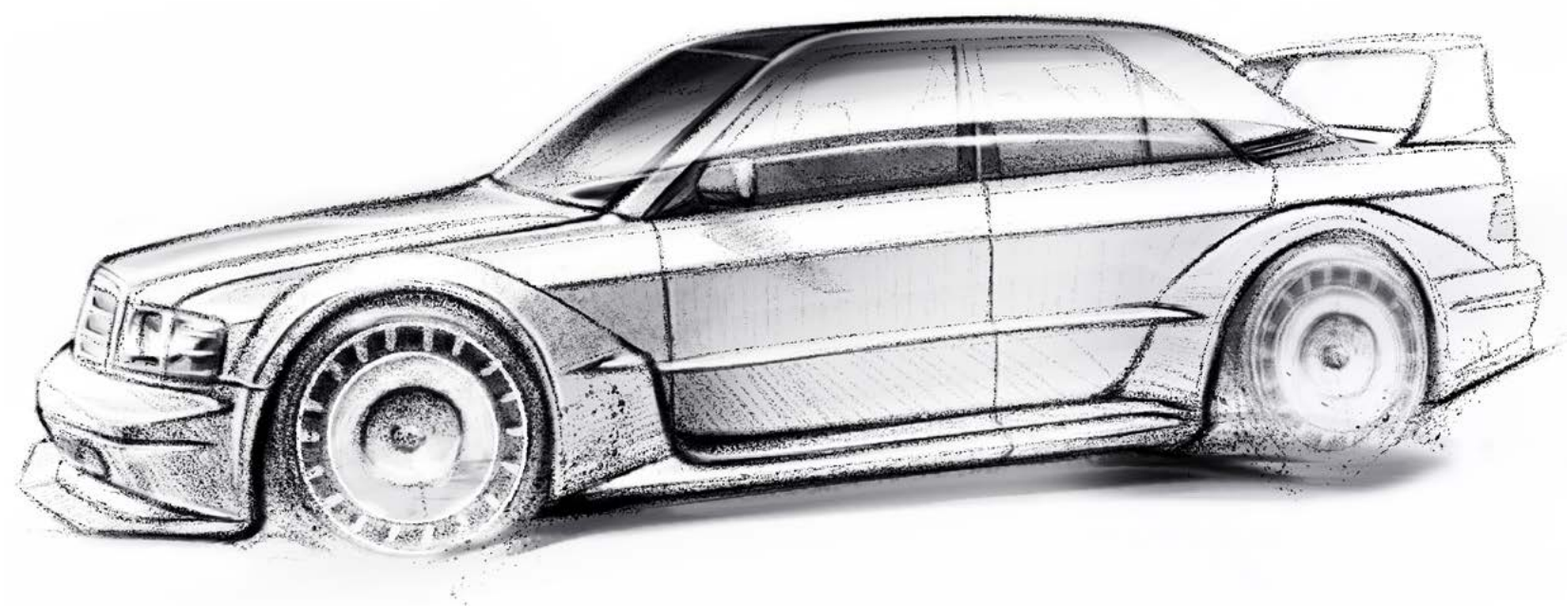

1967

1992

1993

2023

2024

2025

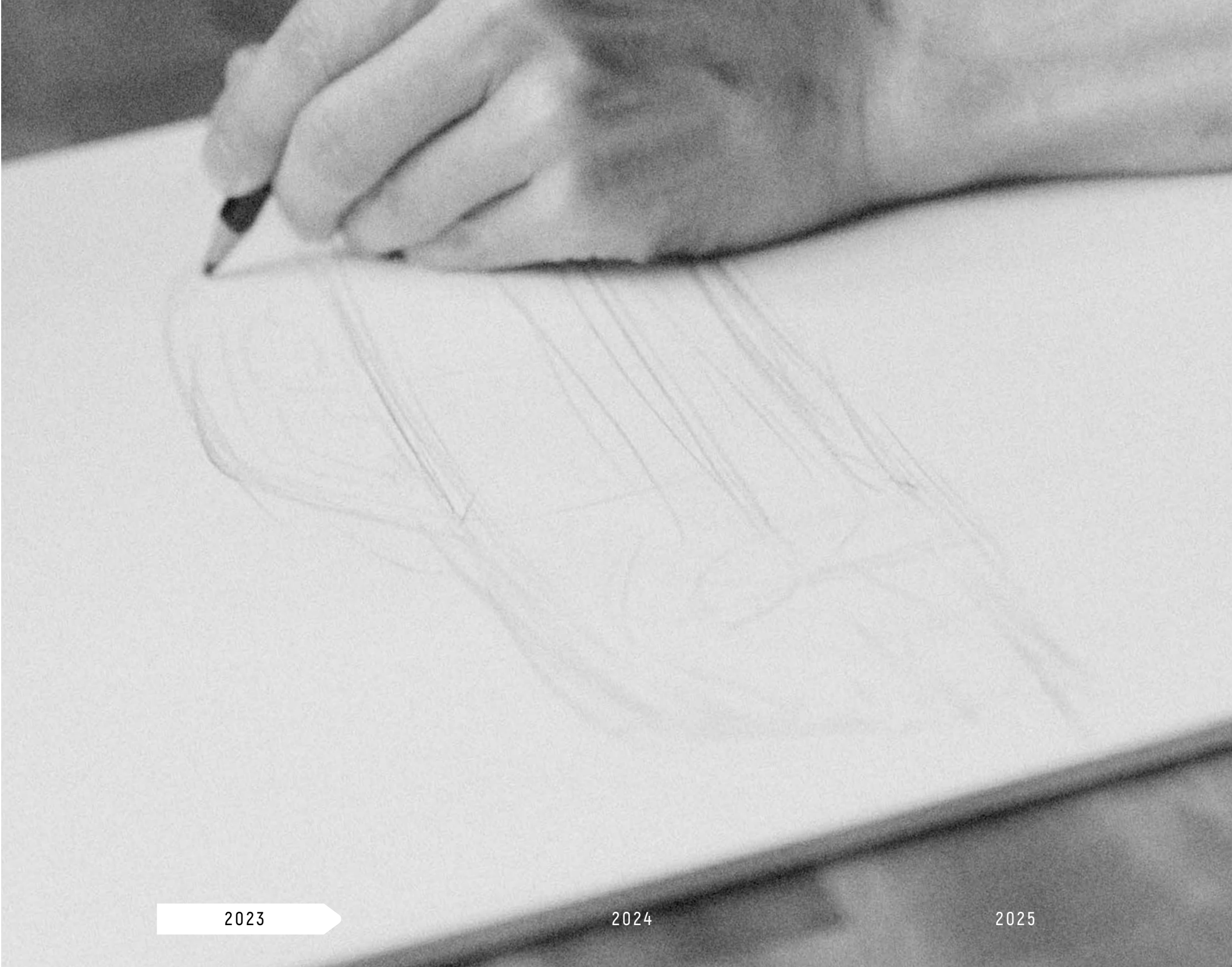

"THE EVO II WAS A STYLE ICON OF THE EARLY 1990S AND SET STANDARDS IN TERMS OF DESIGN. THE IDEA IS TO REINTERPRET THIS DESIGN."

HANS WERNER AUFRECHT

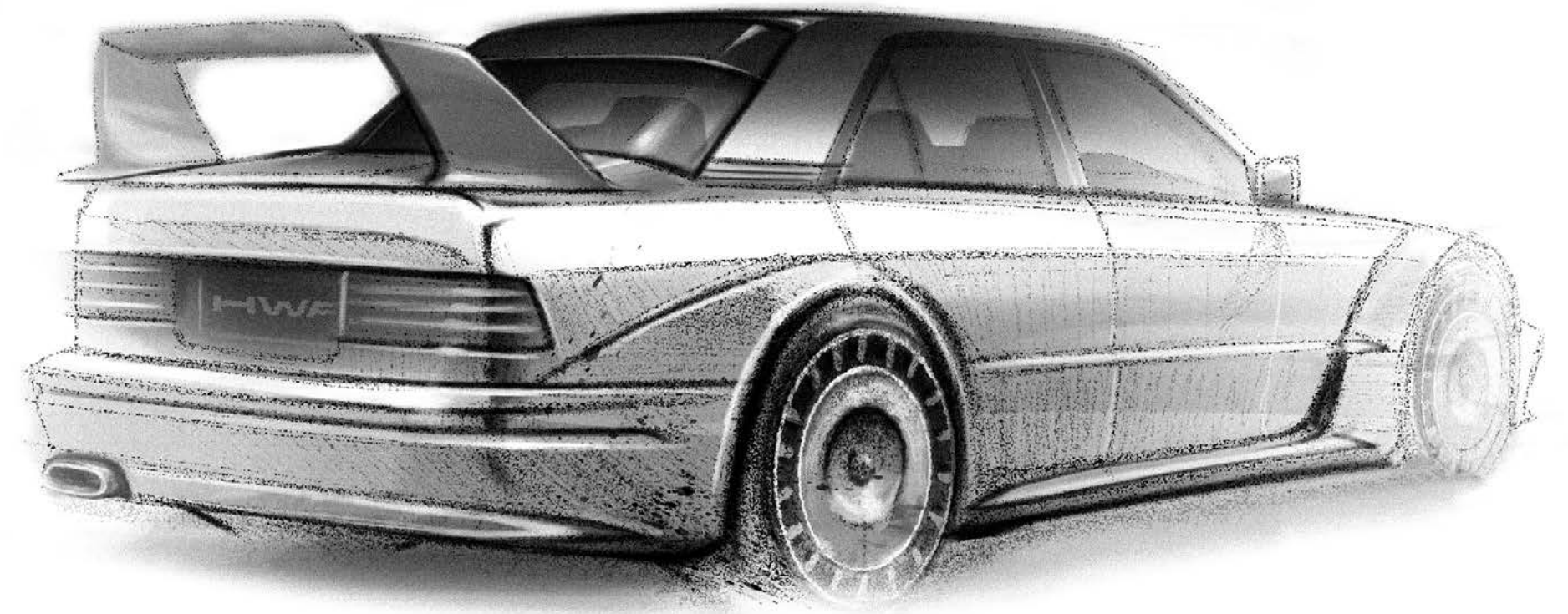

1967

1992

1993

2023

2024

2025

„FORM FOLLOWS FUNCTION, BUT THAT IS NOT ENOUGH BY OUR STANDARDS. FORM ALSO NEEDS TO CREATE MOTION.“

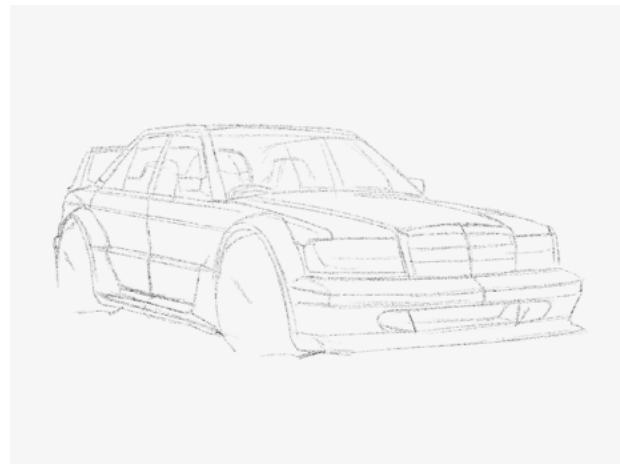

EDGAR CHU, DESIGNER

1967

1992

1993

2023

2024

2025





# THE PROCESS BEHIND

## DONOR VEHICLE



REMOVAL OF ALL PARTS  
(ENGINE, INTERIOR, ELECTRONICS)  
TO GET BODYWORK

## UPCYCLE



CLEAN BODYWORK  
SET-UP THE BASE FOR THE RESTOMOD  
KTL COATING

## RESTOMOD



MODERN TECHNOLOGY  
NEW DESIGN VARIATIONS  
AMG ENGINE

1967

1992

1993

2023

2024

2025

# CAR CONCEPT

VEHICLE EMPTY WEIGHT ACCORDING TO DIN	1350 KG
WEIGHT-DISTRIBUTION	50%
HEIGHT OF CENTER OF GRAVITY	400 MM

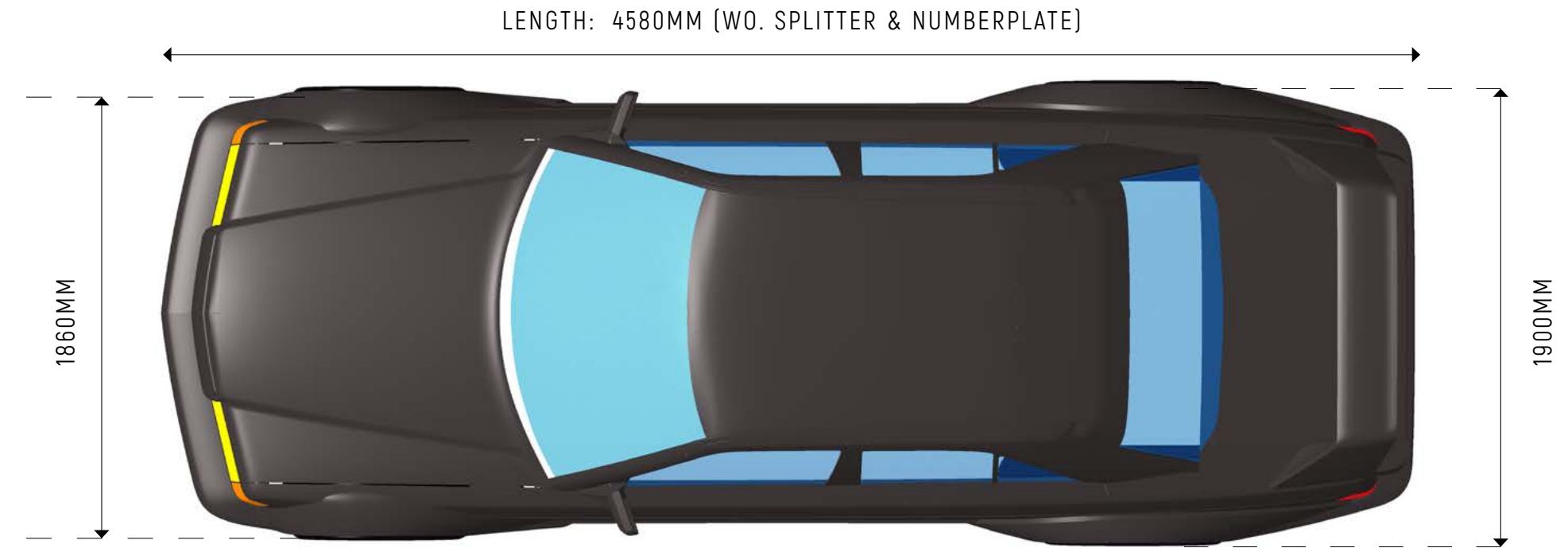
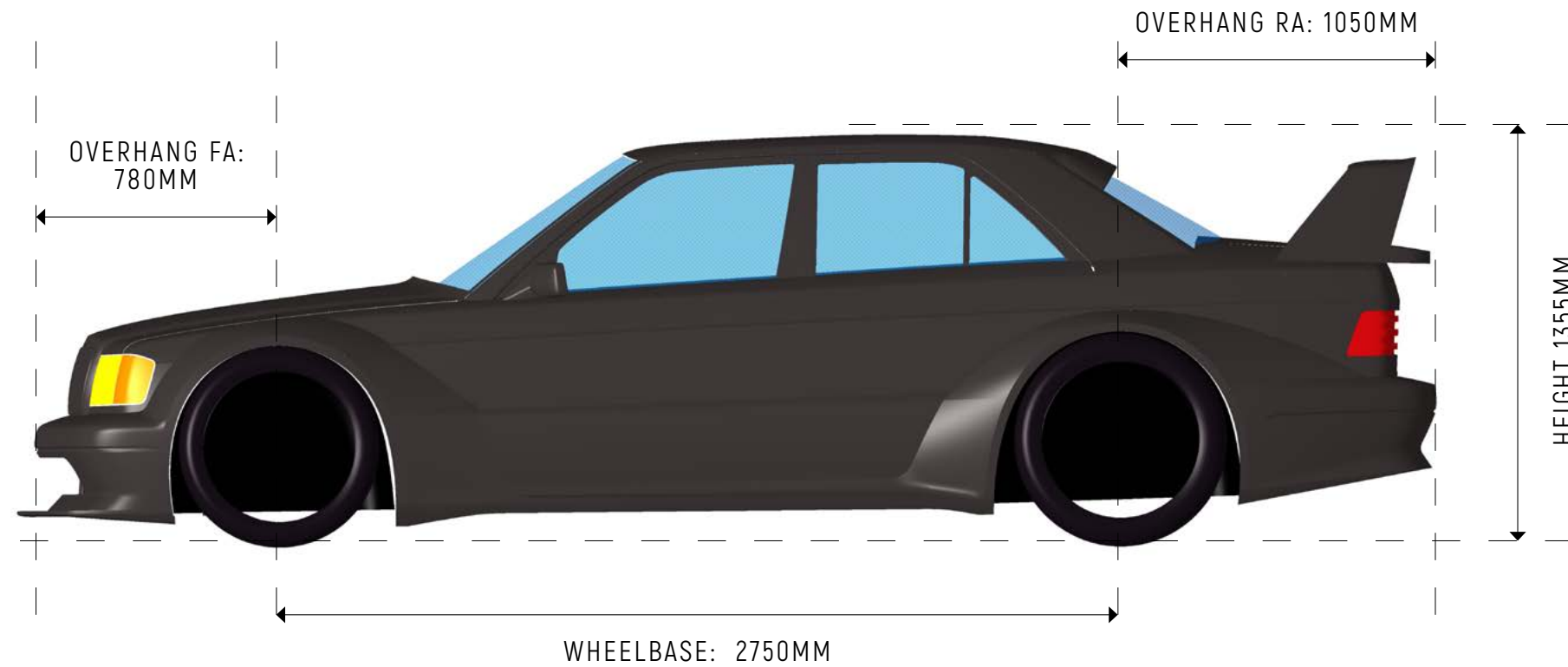

1967

1992

1993

2023

2024

2025

# START YOUR ENGINE

THE HWA EVO IS EQUIPPED WITH A POWERFUL BI-TURBO CHARGED V6 ENGINE THAT WAS BUILT IN SERIES PRODUCTION BUT MODIFIED TOWARDS MORE PERFORMANCE WITH RACING EXPERTISE.

1967

1992

1993

**MERCEDES-BENZ  
ENGINE**  
HWA RACE PACKAGE

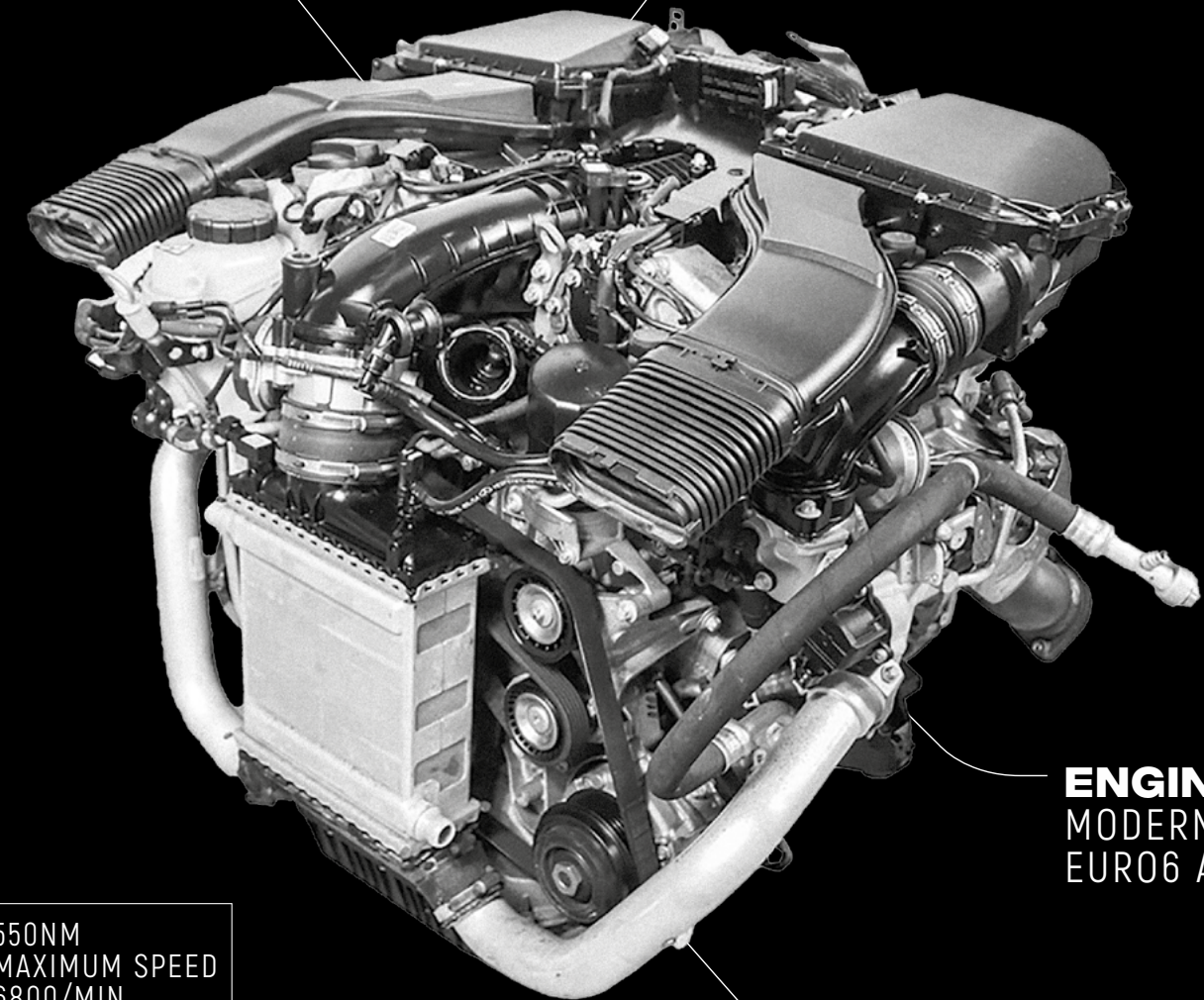

**ENGINE TYPE**  
V6 BITURBO WITH INTERCOOLING

**ENGINE CONTROL**  
MODERN ENGINE CONTROL  
EURO6 AND OBD

**LUBRICATION SYSTEM**  
DRY SUMP LUBRICATION

<b>TORQUE</b>	550NM MAXIMUM SPEED 6800/MIN
<b>DISPLACEMENT</b>	3000CM <sup>3</sup>
<b>POWER</b>	331KW/450HP

2023

2024

2025

# CHASSIS

**CHASSIS**  
EXTENSIVELY OPTIMIZED  
W201 SERIES BODY-IN-WHITE  
NUMBER OF DOORS: 4

**FIA-BASED SAFETY STRUCTURE**  
ENERGY ABSORPTION  
SIDE-INTRUSION  
ROLL-OVER-BEHAVIOUR

**OPTIMIZED**  
TORSIONAL STIFFNESS

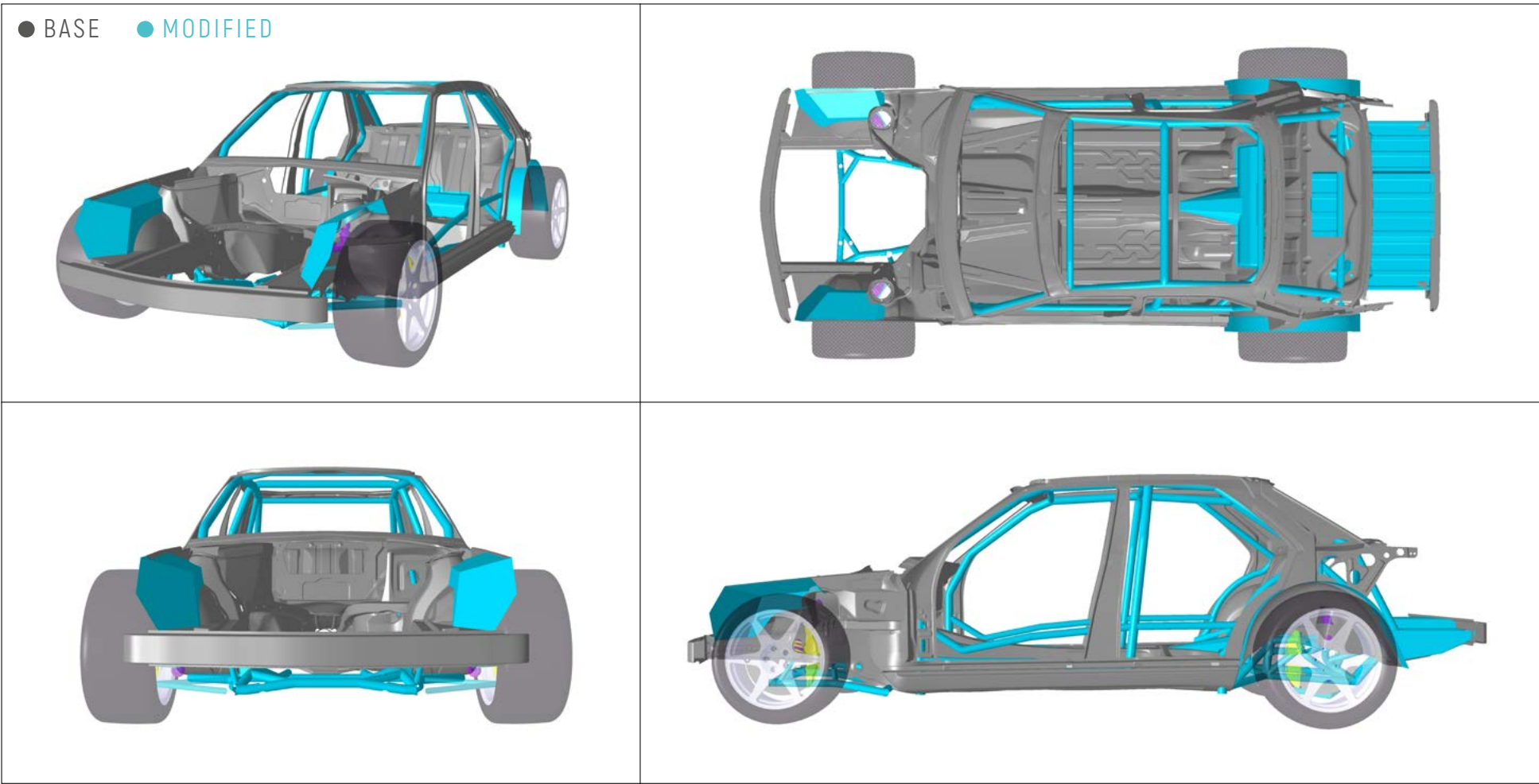

1967

1992

1993

# DRIVE TRAIN

**GEARBOX**  
MANUALLY ACTUATED 6-SPEED GBX  
SUPERCAR GEARBOX

**SHAFTS**  
STEEL SIDESHAFTS  
CARBON DRIVESHAFT

**LAYOUT**  
TRANSAXLE-LAYOUT

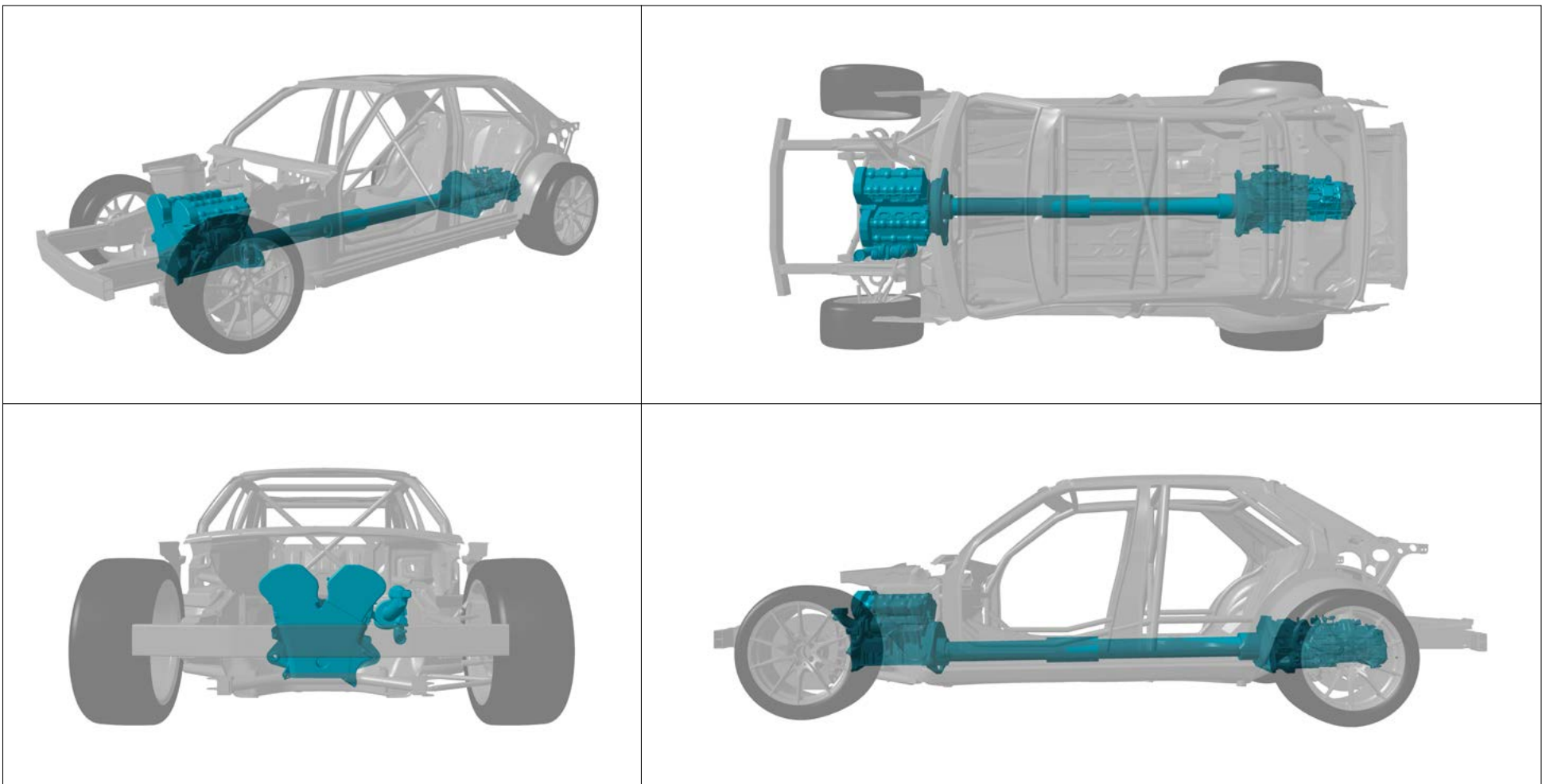

2023

2024

2025

# ORIGINAL LOOK

THE INTERIOR OF THE HWA EVO WILL BE INSPIRED BY ITS ORIGINAL 90S LOOK, SEAMLESSLY INTEGRATING STATE-OF-THE-ART TECHNOLOGY AND DIGITAL COMPONENTS. EVERY ASPECT CAN BE PERSONALIZED ACCORDING TO YOUR INDIVIDUAL IMAGINATION.

1967

1992

1993

2023

2024

2025



**SAFETY**  
SEATBELT TENSIONERS

**CUSTOMIZED  
INTERIOR**

**SEATS**  
RECARO FRONT SEATS

**HMI**  
MODERN, ERGONOMICALLY  
OPTIMIZED HMI

**CONNECTIVITY**  
BLUETOOTH INTERFACE

# SUSPENSION

**AXLE CONCEPT**  
DOUBLE WISHBONE WITH U-STABILIZERS

**BEARING TYPE SUSPENSION**  
**STRUTS** SEALED UNIBALL BEARINGS

**DAMPERS**  
ADJUSTABLE HIGH-PERFORMANCE DAMPER

**GEOMETRIC TRACK WIDTH**  
FRONT / REAR: 1596MM / 1620MM

**WHEELS/TIRES**  
COMPATIBILITY WITH 18" AND 19" RACING  
WHEEL SETS

**CAPABLE BRAKE /  
DRIVE DYNAMICS**  
ESP/ABS SYSTEM

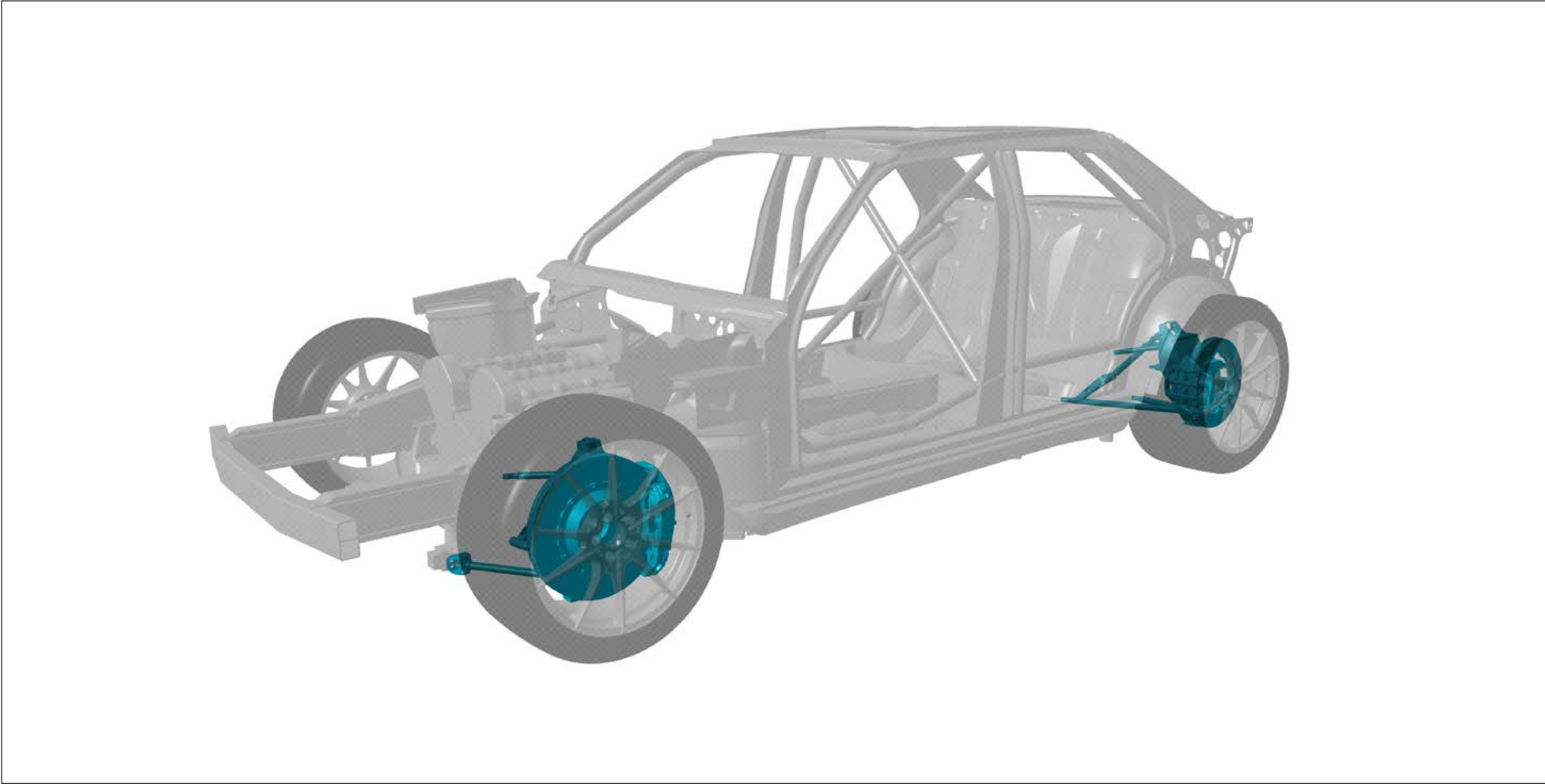

1967

1992

1993

# EXTERIOR

**DESIGN**  
AERODYNAMICALLY OPTIMIZED OUTER  
SKIN BASED ON THE MB 190 EVO II

**MATERIAL**  
EXTENSIVE USE OF CARBON OR  
NATURAL FIBERS

**AERODYNAMICS**  
INTEGRATED, OPTIMIZED COOLING DUCTS  
FOR ENGINE, TRANSMISSION, BRAKES AND  
AUXILIARY UNITS

**STATE-OF-THE-ART**  
EXTERIOR LIGHTING COMPONENTS

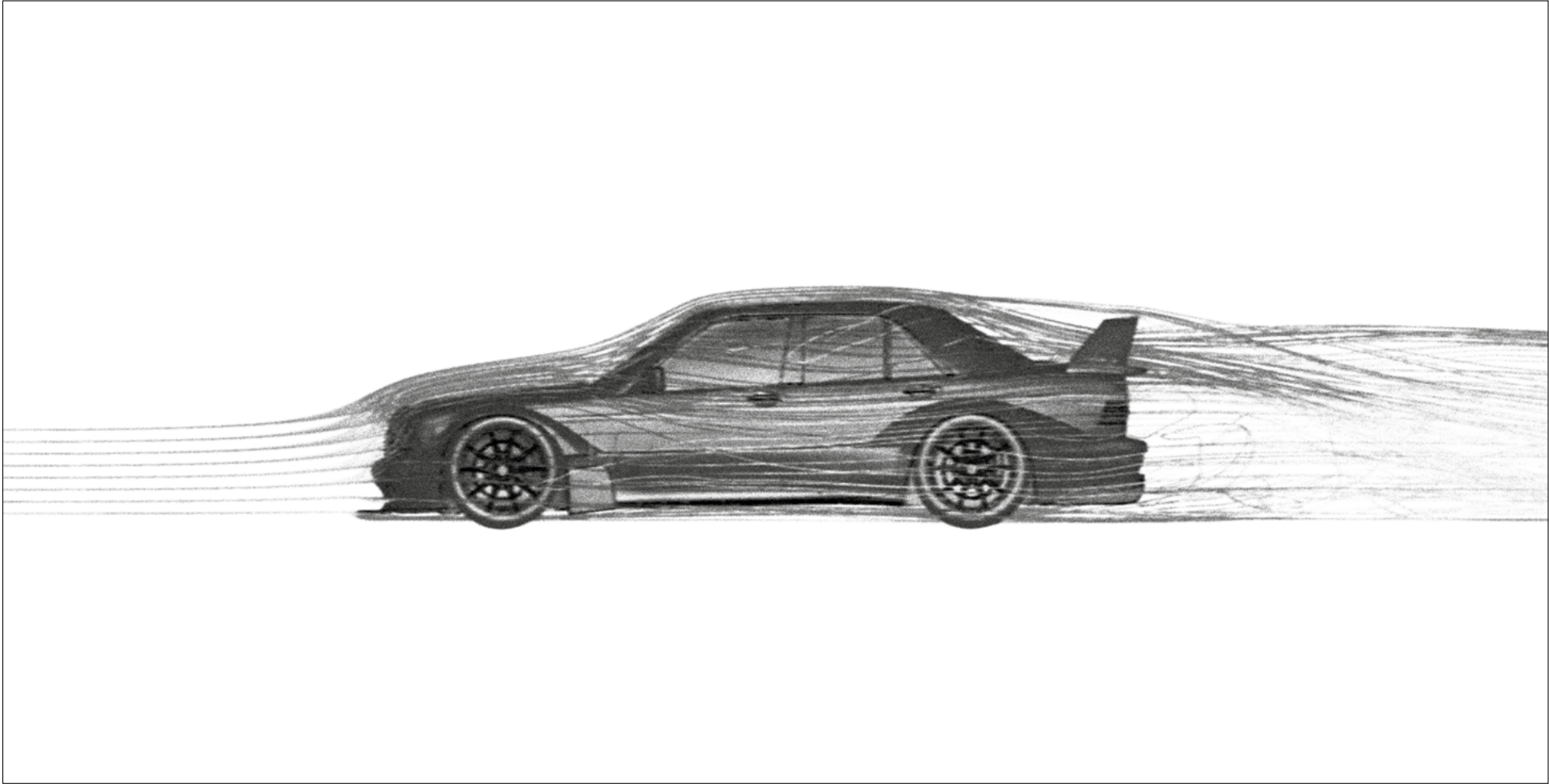

2023

2024

2025

# ICONIC DESIGNS

THE HWA EVO, EMBODYING THE ZENITH OF EXCLUSIVITY, CAN BE PERSONALIZED WITH A SPECTRUM OF UNIQUE COMPONENTS. OPTIONS RANGE FROM CHOOSING AN EXTERIOR COLOR TO SUIT YOUR STYLE, TO SELECTING FROM ICONIC DTM LIVERIES, MERGING CLASSIC RACING HISTORY WITH CONTEMPORARY DESIGN.

1967

1992

1993

2023

2024

2025



# JOIN THE

# JOURNEY

Q4 2023

▶ **JUST FEEL IT**

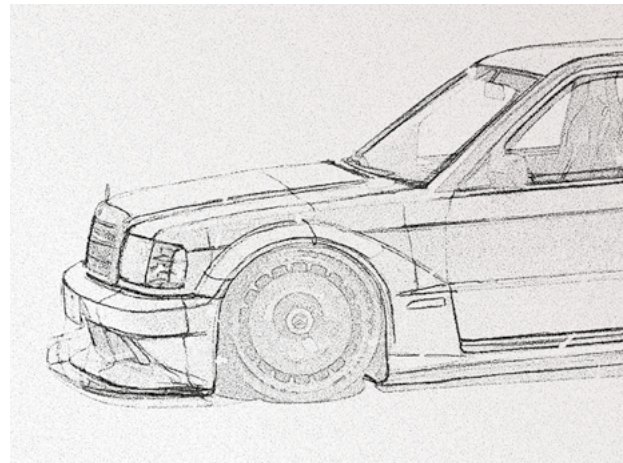

GET IN TOUCH WITH THE 90S AND THE DESIGN LANGUAGE TO CREATE YOUR OWN HWA EVO.

Q1 2024

▶ **GREAT VIEWS**

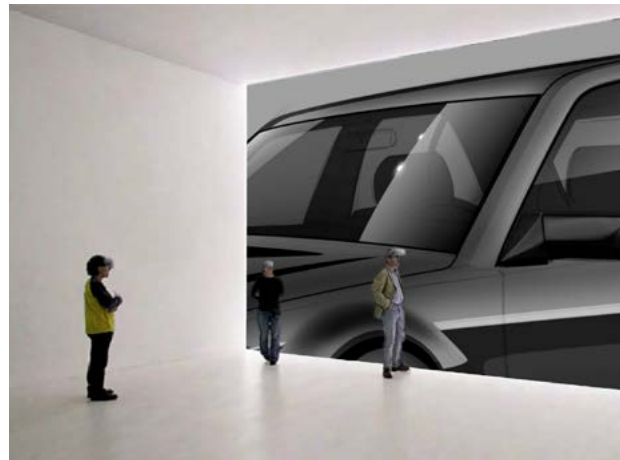

VIRTUAL EXPERIENCE OF YOUR CAR. INDIVIDUALIZED BY YOUR IMAGINATION.

Q2 2024

▶ **TAKE A SEAT PLEASE**



OFFICIAL PRODUCT PRESENTATION.

Q3 2024

▶ **LISTEN TO THE SOUND**



ENGINE FIRE-UP WITH A SOUND THAT GIVES YOU GOOSE BUMPS.

Q3 2025

▶ **ALL TOGETHER NOW**



EXPERIENCE THE FIRST DEMO CAR ON THE TRACK—FEEL, SEE, HEAR.

Q4 2025

▶ **FINAL STINT**



TAKE PART IN THE MANUFACTURING OF YOUR CAR.

1967

1992

1993

2023

2024

2025

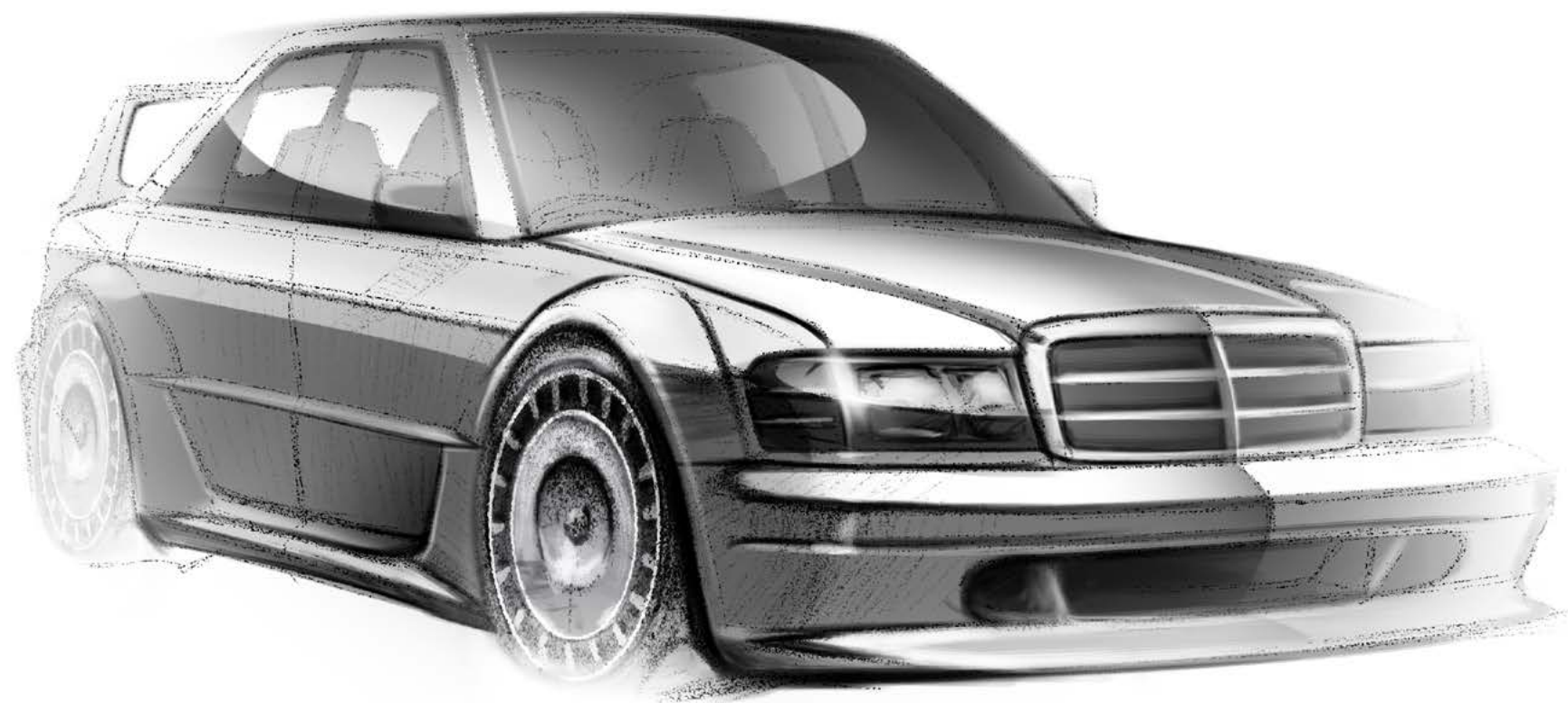

1967

1992

1993

2023

2024

2025

# WHAT YOU GET

LIMITED EDITION	100 PIECES
PRICE OF SALE	FROM 714.000 EURO (PLUS VAT)
DOWNPAYMENT	30 PERCENT UPON SIGNATURE
VEHICLE DELIVERIES	FROM 2025 ONWARDS
USE CASE	ROAD-LEGAL



**PERFORMANCE POWERTRAIN**  
(FRONT - MID ENGINE / TRANSAXLE)



**TRACK APPROVED**  
(COMPONENTS CHECK / RELIABILITY)

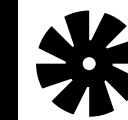

**AERO SIMULATED**  
(VEHICLE DRIVEABILITY)

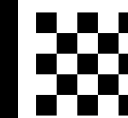

**DTM SUSPENSION**  
(BESPOKE ABS / ESP)

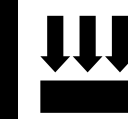

**CARBON BODY-STRUCTURE**  
(DURABILITY / LIGHT-WEIGHT DESIGN)



1967

1992

1993

2023

2024

2025

**CONTACT**

**GORDIAN VON SCHÖNING**  
+49 (173) 7902484

**JOHN TEMERIAN**  
+1 (561) 801-0092

INFO@HWALEGACY.COM  
WWW.HWALEGACY.COM

CHANNELS:  
@HWALEGACY  
@HWALEGACY

**EDITOR**

HWA CARS GMBH  
BENZSTRASSE 8  
71563 AFFALTERBACH  
GERMANY

THE IMAGES IN THIS LOOKBOOK ARE SYMBOL  
IMAGES. THE FINAL PRODUCT MAY DIFFER FROM  
THE INFORMATION SHOWN

LOOKBOOK VERSION:  
NOVEMBER 2023



**HWA**